

Optimum operating temperature in a water-cooled engine is provided by a system that circulates coolant through the engine block water jacket and the radiator. The water pump is the mechanism that maintains the constant flow of coolant. In most cases, the water pump is driven by a belt pulley system, where the pulley receives power from the engine's drive belt, timing belt, or fan belt.

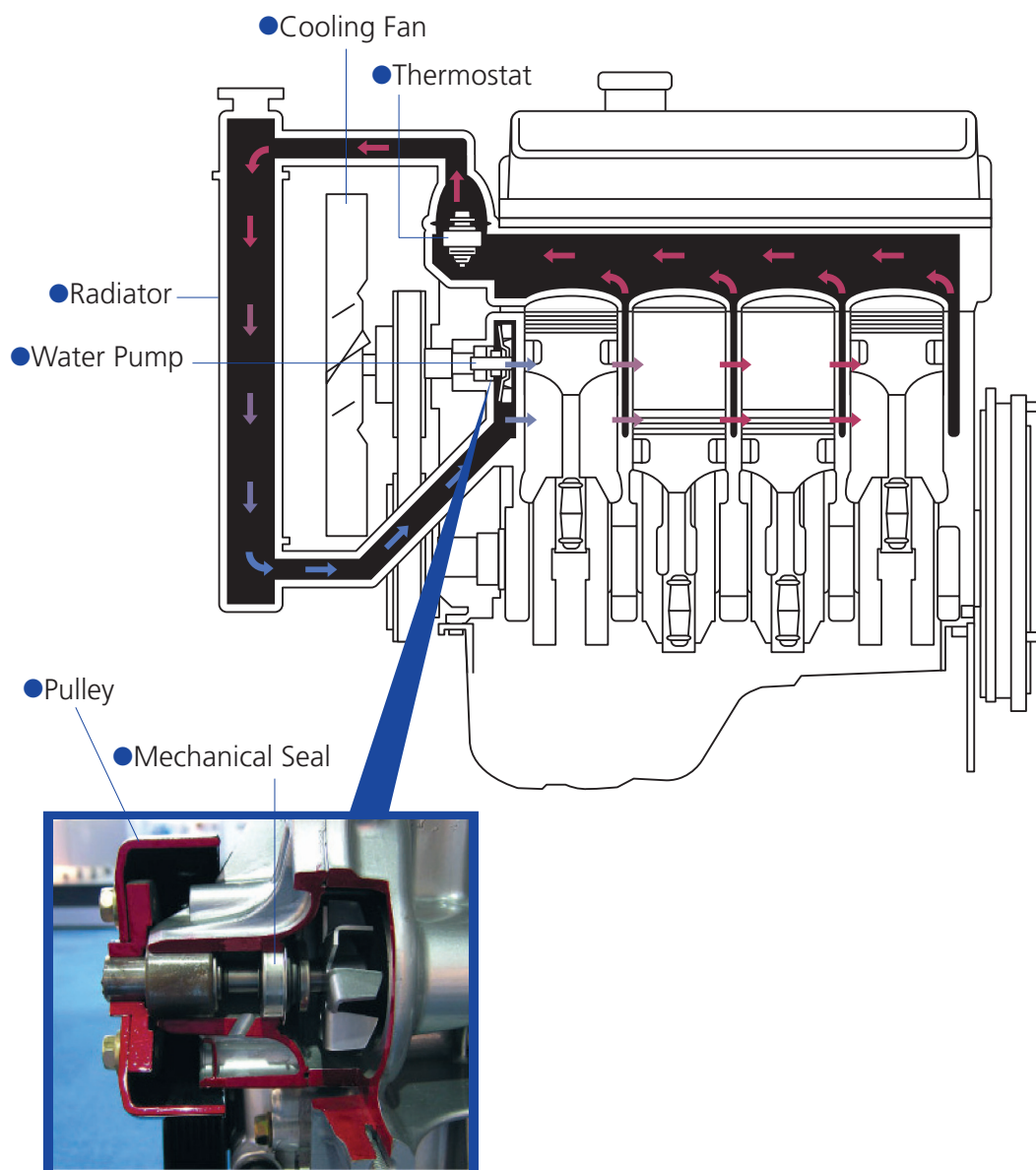

2 Structure and Components



The structure of the water pump is comprised of the following components: pulley hub, body, shaft, bearing, mechanical seal and rotor (impeller). The shaft is mounted onto a bearing which is pressed into the water pump body. On one end of the shaft, a pulley hub is attached, while the other end is a rotor (impeller). The pulley hub transfers energy from the fan or timing belt into a rotation, spinning the shaft, therefore spinning the rotor. The rotor then circulates the coolant. A mechanical seal is installed to prevent leakage of coolant into the bearing and also supports the shaft for smooth rotation.

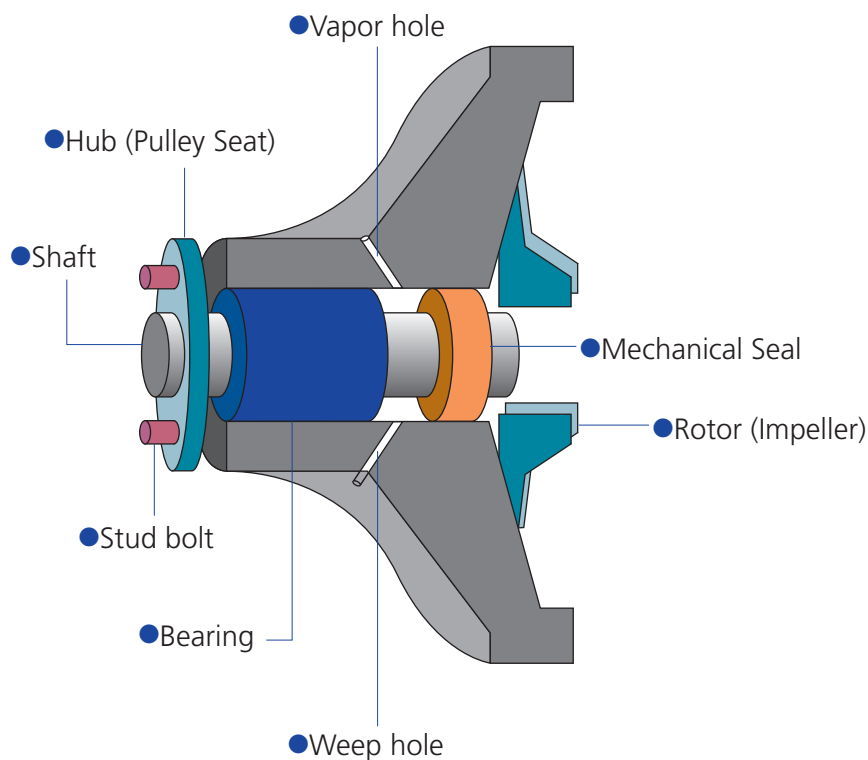

The body of the water pump is equipped with a vapor hole and a weep hole. The vapor hole relieves excess gas pressure seeping through the mechanical seal. The weep hole bleeds off excess coolant seeping through the mechanical seal. Both holes function as a safety to protect the shaft and the bearing from contamination.

Bearing

●Wear Resistance

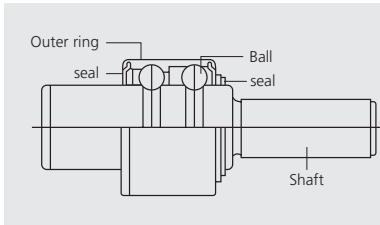

The bearing relieves pressure on the shaft from the tension created by the fan or timing belt. Since pressure is continuously applied, a high quality bearing is of the utmost importance to protect the water pump from failing.

Mechanical Seal

● Leakage Resistance

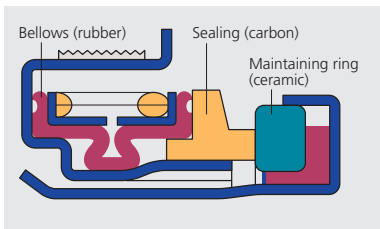

The mechanical seal prevents coolant leak as well as support the rotation of the shaft. The structure of the airtight seal and durable materials used also prevents unneeded noise and vibrations.

Pump Rotor

●Corrosion Resistance

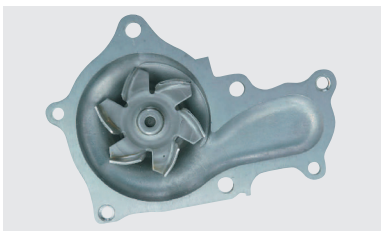

Quality materials for the rotor are a necessity to create and maintain complex geometry for the optimization of coolant flow, as well as resisting corrosion from rust, scaling of coolant and cavitation.

Pump Body

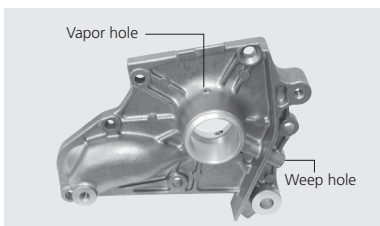

Quality materials are used to withstand heat, vibration and corrosion. Water channel is designed with optimal flow of coolant. Positioning of vapor hole and weep hole are key to prevent excess coolant from bearing and shaft contamination.



4 Precautions in Handling

Do not manually turn the pulley before installation of the water pump. In the mechanical seal, the soft carbon block may create residue on the ceramic block, generating abnormal (squealing) noises during operation.

1. Do not dry turn the pulley!

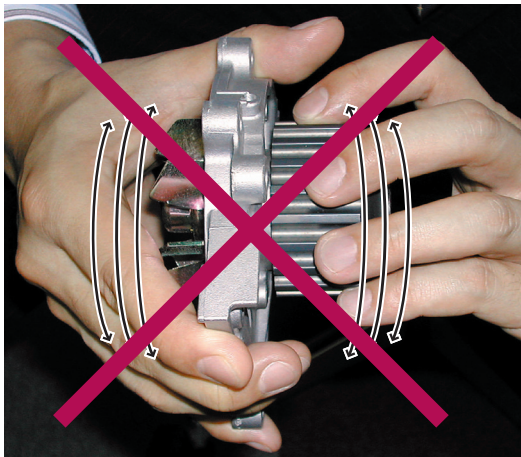

WARNING!
Dry turning will damage the mechanical seal. Pre-lubricate before turning.

2. Seal Damage Example: Mechanical Seal Inner View

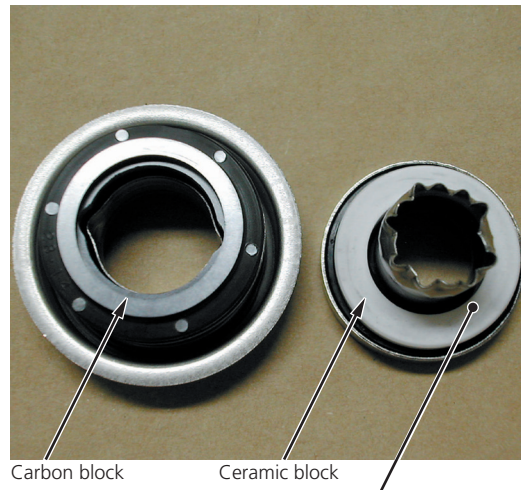

Dry turning will deposit carbon onto the ceramic block, causing squealing during operation.

3. Pre-lubrication

Submerge the lower part of the pump body and the base of the rotor.

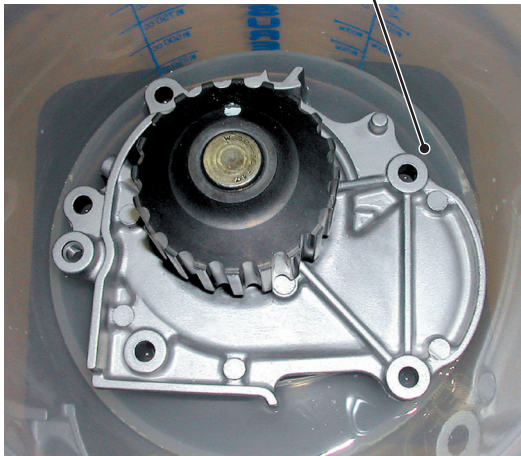

4. Water level

Caution: Do not submerge the weep hole or vapor hole in water.

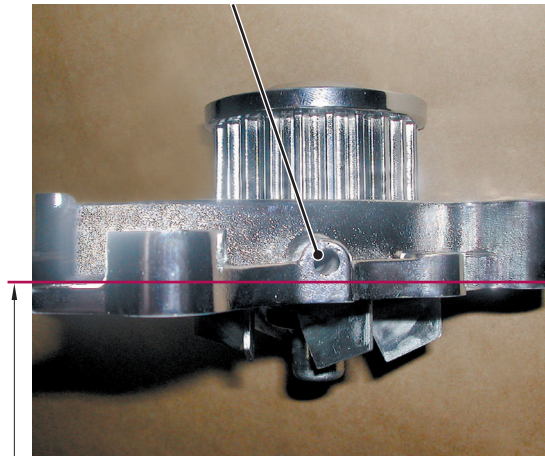

Submerge the water pump body below the red line

Precautions

It is recommended that the lower part of the water pump is submerged in water for approximately 3 minutes prior to installation. This is to form a layer of water between the carbon and ceramic blocks in the mechanical seal, and prevent abnormal (squealing) noises from being generated. (Some noise may be heard at initial start-up, but will disappear after engine warm-up.)

5

Installation Procedure

1

Flush the radiator 2-3 times with water while letting the engine idle. This will remove scale, rust deposits and sludge from the coolant system.

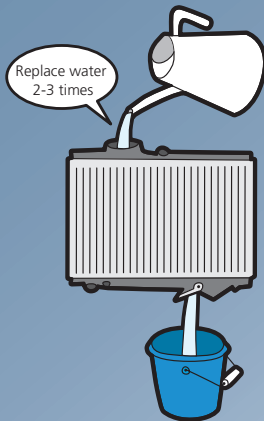

Why?

Prevents foreign materials from contaminating the new water pump mechanical seal.

2

After engine is cooled down, drain water from step 1, remove old pump, gaskets and foreign materials left on the mounting surface. Thoroughly clean with non-abrasive solvent.

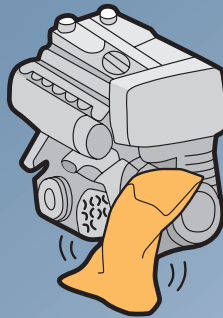

Why?

Prevents leakage from the mounting surface.

3

If a sealant is needed, apply an even amount around the pump. Wipe off excess and make sure the sealant(RTV) does not intrude into the water channel.

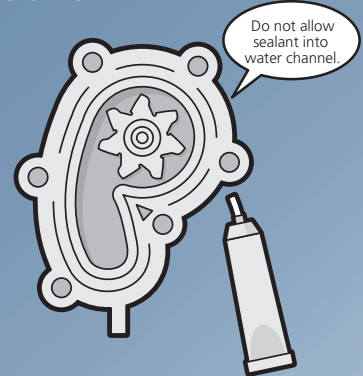

Why?

Excess sealant material may damage the mechanical seal, which may cause pump failure.

4

Install the new water pump in a diagonal (star) pattern and apply torque specified by the vehicle manufacturer. Allow sealant(RTV) to cure if applied.

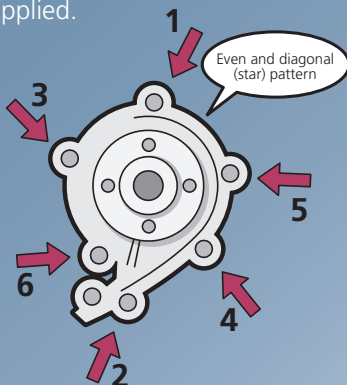

Why?

- Prevents leakage from the mounting surface.
- Prevents body damage from installation.
- Prevents body fractures caused by belt tension.

5

Confirm that the fan coupling is free of rust and contaminants. After installation, verify run-out tolerances specified by the manufacturer using a dial indicator.



Why?

Prevents fractures and damage caused by backlash or wobble of the pulley or fan coupling.

6

Install the fan belt or timing belt and apply tension specified by the manufacturer.

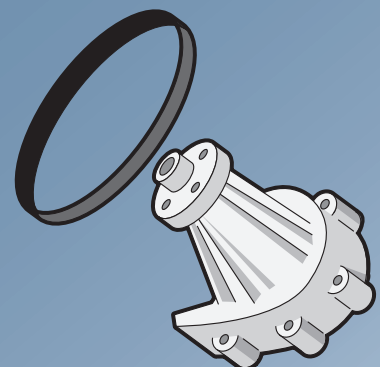

Why?

- Prevents fractures and damages caused by belt tension.
- Prevents noise.



7

Refill with new coolant (LLC) to the mixture amount and volume specified by the vehicle manufacturer.

Why? Insufficient amount or incorrect mixture of coolant (LLC) will cause abnormal wear of the mechanical seal, which will cause coolant leak.

8

Bleed the air completely to ensure the engine, pump, radiator and reservoir are filled with the manufacturer specified amount of coolant.

Why?

- Insufficient amount or incorrect mixture of coolant (LLC) will cause abnormal wear of the mechanical seal, which will cause coolant leak.
- Air bubbles may create additional cavitation which will corrode the rotor.

9

Reconfirm the amount of coolant(LLC) and belt tension. Start the engine and look for leaks.

Why?

- Prevents coolant leak under normal operation.
- Prevents damage from installation



Caution

Failure to follow recommended procedures may cause engine failure and injury.

Failure Rate by Cause (Customer complaints)

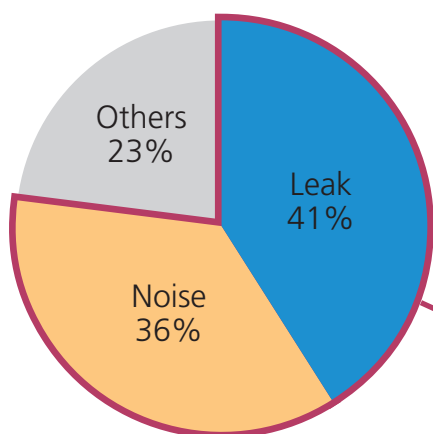

More than 75% of failures are due to complaints related to coolant leaks and noise occurring from the water pump. To prevent most water pump problems from occurring, follow the 4 key steps described in the installation procedures from steps:

- 1** Flush the radiator and coolant system regularly
- 6** Tighten belt to vehicle manufacture specified tension
- 7** Re-fill with new coolant (LLC)
- 8** Bleed air completely

1 Weep Hole Coolant Leak

Condition

- The weep hole protects bearings from corrosion damage by preventing seepage of coolant into the pump body.
- In normal operation, traces of dried coolant may be visible around the hole. Coolant leak may be occurring if there is fluid around the weep hole or if the reservoir tank reaches low coolant levels within about a month.

Cause

- Contamination and sludge has damaged the mechanical seal, reducing sealing performance.

Cure

- Before installing the new water pump, flush the cooling system 2 - 3 times and let engine idle for about 3 minutes with the old pump to remove any sludge deposit.
- Replace the anti-freeze regularly at the specified mixture and fluid level.
- Do not use sealants (RTV) when gaskets are supplied.
- When sealants are necessary, apply evenly and do not allow excess to enter the water channel.

① Coolant degradation



New



38,000 km (23,000 miles) 4 years old

ATTENTION

- Older coolants have higher risks of leakage.
- Always flush the radiator and replace with new coolant.
 - Replace coolant regularly.



② Fair and Poor, leak from the weep hole

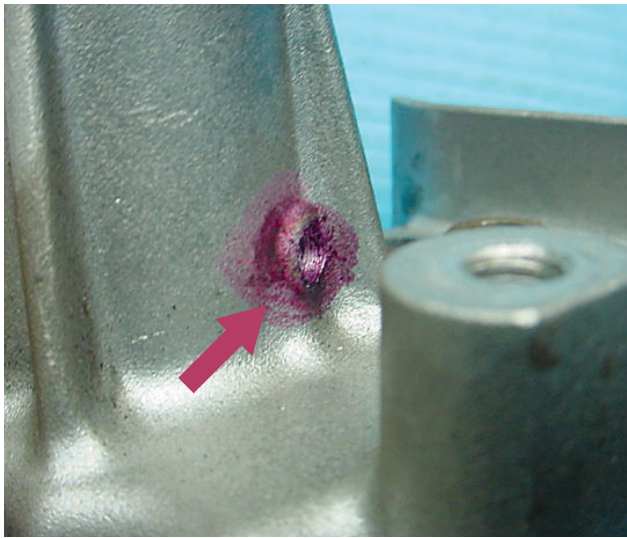

Normal Dried coolant residue.

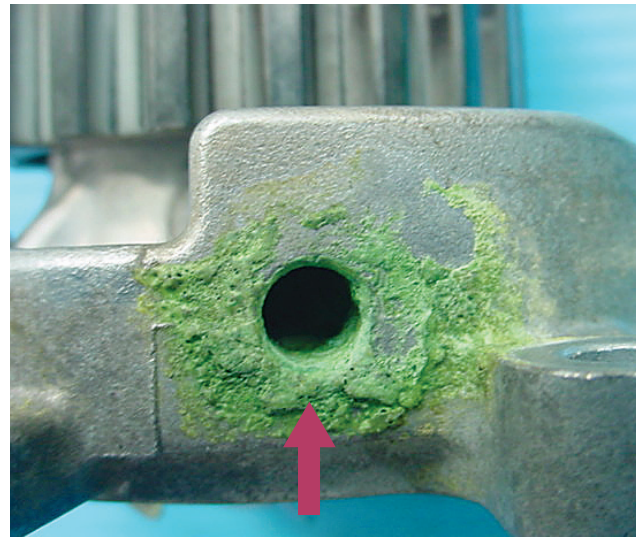

Damaged Large coolant bleed mark, dampness or dripping.

③ Fair and Poor, mechanical seal ceramic

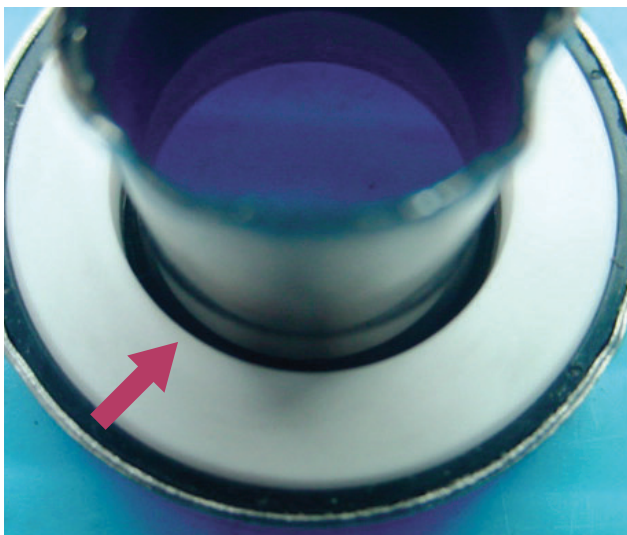

Normal Clean ceramic.

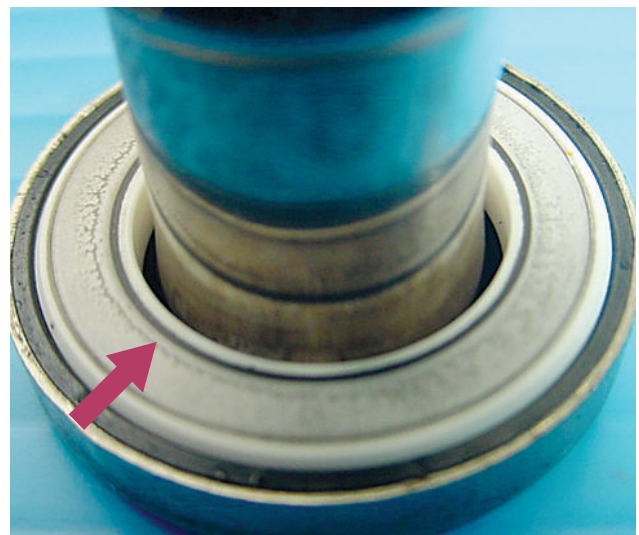

Damaged Accumulated sludge (Contaminated coolant).

2 Seepage

Condition

- Seepage from the mounting surface

Cause

- Deterioration of the sealing performance caused by unevenly applied sealant (RTV)
- Deterioration of the sealing performance caused by the use of adhesives
- Sealants used on the O-ring deteriorated the elasticity of the rubber
- Unevenly tightened bolts
- Contamination (dirt/grime) on mounting surface
- Mounting surface dented caused by mishandling
- Fractured/deformed gasket

Cure

- Use manufacturer's specified sealant if it is designated
- Do not use sealants when gaskets are supplied
- Do not use adhesives in place of sealants or gaskets
- Install the new water pump in a diagonal (star) pattern and apply torque specified by the vehicle manufacturer
- Clean mounting surface free of contaminants
- Do not re-use old gaskets and previously applied sealant



① Poor application of sealant



Sealant has interfered with the mechanical seal causing leaks.

② Excess torque of the mounting bolt

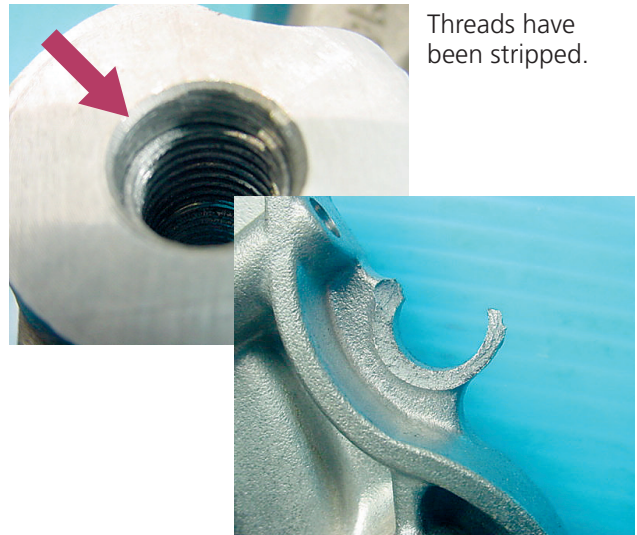

Threads have been stripped.

Unevenly tightened or over torqued.

③ Poor cleaning of the mounting surface

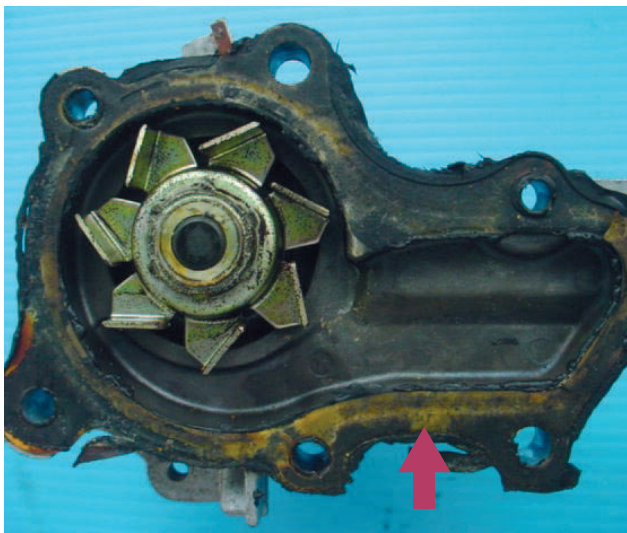

Insufficient accuracy on the mounting surface.

④ Sealant used on supplied gasket



Gasket performance has degraded.

3 Overheating

Condition

- Corrosion of the impeller
- Fracture of the bearing
- Internal corrosion of the water pump body

Cause

- Old coolant
- Coolant deterioration
- Insufficient flushing of the radiator
- Low concentration of coolant
- Lack of coolant

Cure

- Discontinue use of old coolant
- Fully flush the radiator
- Replace coolant with manufacturer's specified mixture and fluid level
- Purge air from system

① Coolant degradation

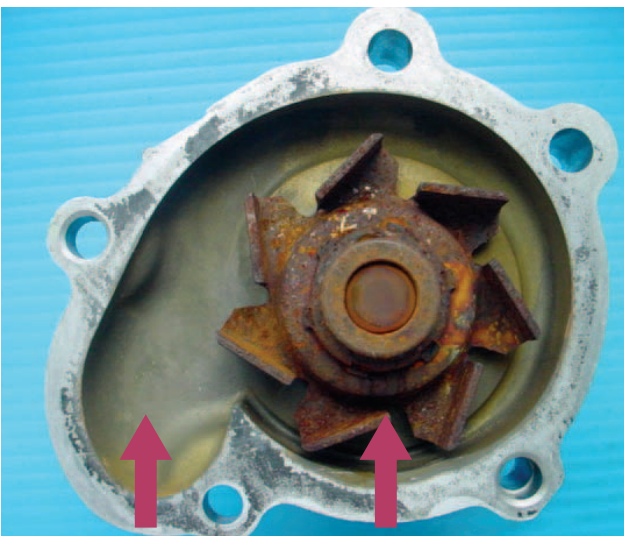

Contamination of
water pump body

Impeller corrosion

② Cavitation



Cavitation



Coolant

When replacing the water pump, flush the coolant system 2 to 3 times to wash out sludge, scale and rust deposits. Replace coolant to the manufacturer's specified mixture and fluid level. Re-using or using degraded coolant will corrode the body, impeller, and mechanical seals.

① Severely corroded impeller



② Fracture caused by cavitation

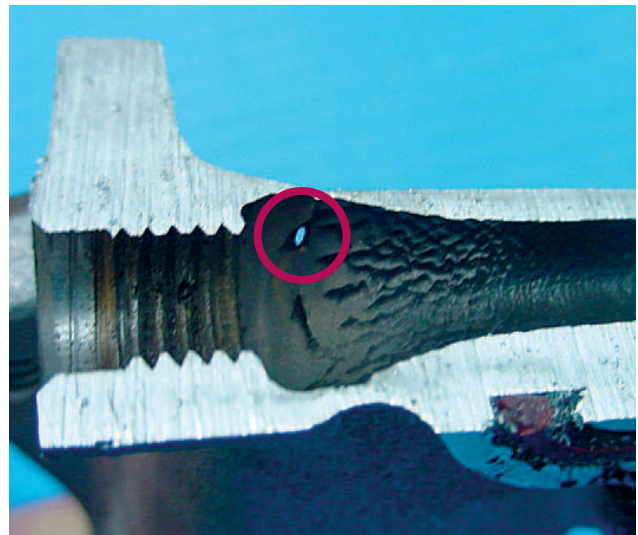

Corrosion of impeller

No corrosion can be seen on the impeller when the coolant is clean.

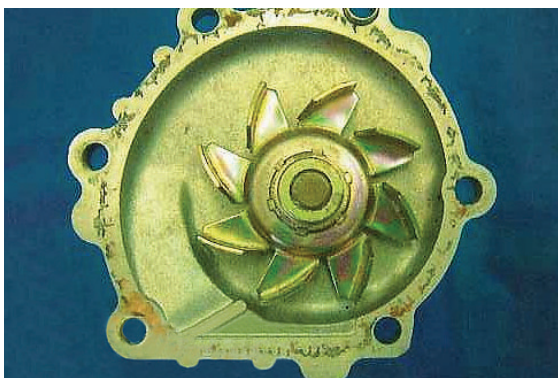

Mileage: 48,000 km (30,000 miles)
Period: Approximately 1.6 years
Total mileage: 149,000 km (92,500 miles)

Corrosion can be seen on the impeller when the coolant is degraded (contaminated / deteriorated).

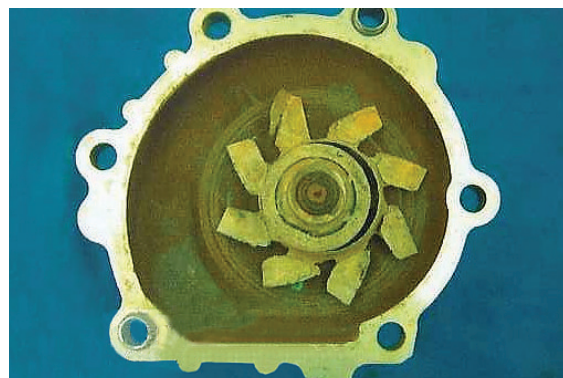

Mileage: 7,500 km (4,700 miles)
Period: Approximately 1 year
Total mileage: 105,000 km (65,000 miles)

4 Abnormal Noises

Condition

- Rumbling sound heard when manually turning the pulley
- Abnormal wear at the base of the stud bolts
- Excessive run-out of the pulley seat

Cause

- Bearing fracture caused by excess belt tension
- Bearing was fractured due to excess vibrations caused by misalignment of parts such as the fan coupling pulley
- Uneven torque of bolts resulted in bearing failure
- Contamination of the pulley seat

Cure

- Tighten belt tension to vehicle manufacturer specifications
- If the fan coupling pulley is reused, confirm the run-out with a dial indicator
- Replace fan coupling pulley with new on older vehicles or high mileage engines
- Confirm that the bearing is lubed and no rumbling sound is heard, and replace if necessary

Flecking at the bearing



Damage due to overload and seepage



Trouble caused by incorrectly installed or damaged fan coupling

Condition

- Fracture of the water pump body
- Fracture of the water pump bearing

Cause

- Reused damaged fan coupling
- Fan coupling was not installed correctly (off-centered)

Cure

- Install new fan coupling when replacing water pump
- If fan coupling is reused, ensure that:
 - there is no binding or play in the bearing
 - bearing seal plate is securely fastened
 - the components are free of rust and debris
 - check for run-out with a dial indicator

① Enlarged view of a fan coupling

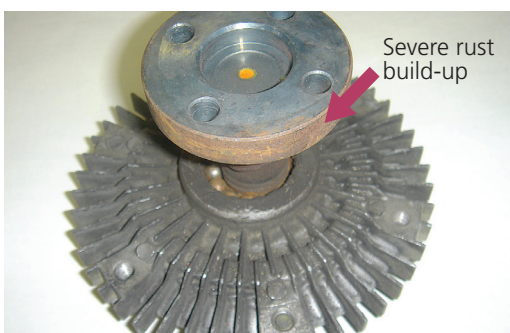
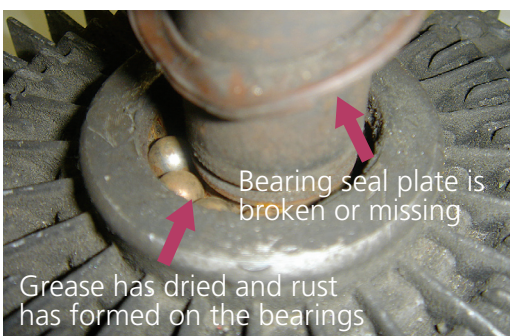

If usage is continued

② Fractured bearing

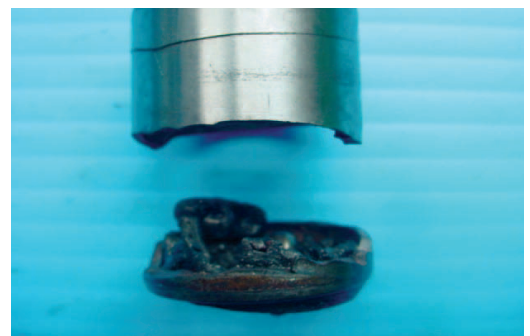

③ Fractured body



Water Pump Failures

Leakage

Location	Symptom	Cause
Weep hole	Foreign material caught in the mechanical seal	<ul style="list-style-type: none"> ● Rusting caused by coolant degradation ● Excess sealant (RTV) entered the water pump cavity
	Rough surface of the mechanical seal	<ul style="list-style-type: none"> ● Rust caused by coolant degradation ● Insufficient cleaning of the radiator
	Burned mechanical seal	<ul style="list-style-type: none"> ● Engine started without coolant
	Fracture of mechanical seal or bearing	<ul style="list-style-type: none"> ● Excessive pulley tension
Mounting surface	Contamination (dirt/grime)	<ul style="list-style-type: none"> ● Insufficient removal of sludge on the engine mounting surface
	Installation error	<ul style="list-style-type: none"> ● Damage/deformation of the mounting surface ● Sealant (RTV) applied unevenly ● Bolts tightened unevenly
	Fractured/deformed gasket	<ul style="list-style-type: none"> ● Gasket damaged in shipping ● Bolts tightened unevenly or an impact wrench was used
Body fracture	Cavitation	<ul style="list-style-type: none"> ● Coolant degradation ● Insufficient air bleeding ● Insufficient flushing of the radiator
	Body fracture	<ul style="list-style-type: none"> ● Excessive pulley tension ● Wobble of the pulley
	Mounting screw fracture	<ul style="list-style-type: none"> ● Bolts were tightened excessively



Water Pump Failures

Abnormal noise

Location	Symptom	Cause
Bearing	Noise: Rumbling Locked bearing	<ul style="list-style-type: none"> ● Bearing fracture caused by excess belt tension ● Bearing fracture caused by excess vibration of the fan coupling pulley
Mechanical seal	Noise: Whining	<ul style="list-style-type: none"> ● Dry turning of the pulley caused carbon residue to form on the ceramic block ● Engine started without coolant
Pulley	Noise: Squeak	<ul style="list-style-type: none"> ● Slipping belt (insufficient belt tension)

Water Pump Failures

Others

Location	Symptom	Cause
Run-out of the rotor	Damaged crimp	<ul style="list-style-type: none"> ● Corrosion caused by coolant degradation ● Insufficient flushing of the radiator
Impeller corrosion	Impeller wear/corrosion	<ul style="list-style-type: none"> ● Corrosion caused by coolant degradation ● Insufficient flushing of the radiator
Run-out of the pulley or bearing	Pressure Leak	<ul style="list-style-type: none"> ● Excessive run-out of the fan coupling pulley ● Contamination (dirt/grime) on the mounting surface